

PERFILES ESTRUCTURALES

PERFIL SILO

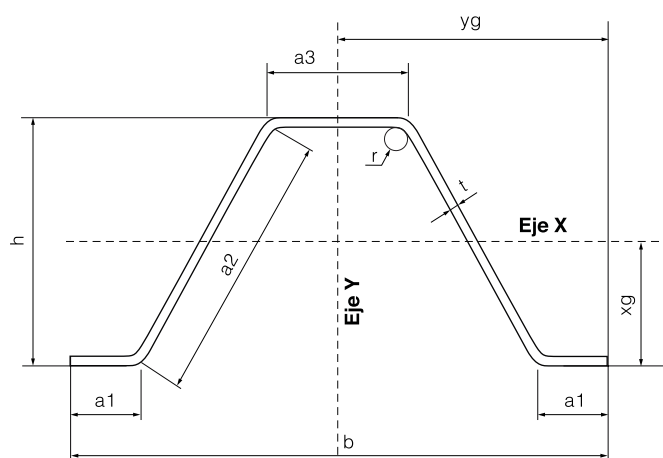

PENTA-KA S.A.



PERFIL SILO

Medidas y características geométricas

Nombre	Descripción
a1 mm	Pestañas (Rigidizador o Labio total)
a2 mm	Alas angular (Ancho total)
a3 mm	Alma angular (Alto angular)
b mm	Ancho total
t mm	Espesor
r mm	Radio Interno
a cm ²	Sección
g Kg/m	Peso

Nombre	Descripción
h mm	Alma (Alto total)
Jx cm ⁴	Inercia respecto al eje X
ix cm	Módulo resistencia respecto al eje X
wx=wy cm ³	Radio de giro respecto al eje X/Y
xg mm	Distancia media del alto
Jy cm ⁴	Inercia respecto al eje Y
iy cm	Módulo resistencia respecto al eje Y
yg mm	Distancia media del ancho

a2 mm	a3 mm	a1 mm	b mm	t=r mm	a cm ²	g Kg/m	h mm	Jx cm ⁴	ix cm	wx cm ³	xg mm	Jy cm ⁴	iy cm	wy cm ³	yg mm
101	50	25	190	1,60	4,77	3,79	90	51,24	3,28	11,39	45	133,46	5,29	14,05	95
101	50	25	190	2,00	5,92	4,74	90	63,00	3,26	14,00	45	165,76	5,29	17,45	95
101	50	25	190	2,50	7,33	5,92	90	77,17	3,24	17,15	45	205,71	5,30	21,65	95
101	50	25	190	3,20	9,38	7,58	90	96,63	3,21	21,47	45	263,21	5,30	27,71	95